



F900 SERIES

User, installation and servicing instructions

RISE and FALL GRILL

E600

Read these instructions before use

DATE PURCHASED:

MODEL NUMBER:

SERIAL NUMBER:

DEALER:

SERVICE PROVIDER:

T100913

REV. 2

Dear Customer,
Thank you for choosing Falcon Foodservice Equipment.

This manual can be downloaded from www.falconfoodservice.com or scan here.



IMPORTANT: Please keep this manual for future reference.

Falcon Foodservice Equipment

HEAD OFFICE

Wallace View, Hillfoots Road, Stirling. FK9 5PY. Scotland.



WEEE Directive Registration No. WEE/DC0059TT/PRO

At end of appliance life, dispose of appliance and any replacement parts in a safe manner, via a licensed waste handler. Appliances are designed to be dismantled easily and recycling of all material is encouraged whenever practicable.



- **These instructions are only valid if the country code appears on the appliance. If the code does not appear on the appliance, refer to the technical instructions for adapting the appliance to the conditions for use in that country.**
- **Installation must meet national or local regulations. Attention must be paid to: gas safety (installation & use) regulations, health and safety at work act, local and national building regulations, fire precautions act.**
- **To prevent shocks, all appliances must be earthed.**
- **This appliance has been CE-marked on the basis of compliance with the Low Voltage and EMC Directives for the voltages stated on the data plate.**
- **This equipment is for professional use only and must be used by qualified persons.**
- **The installer must instruct the responsible person(s) of the correct operation and maintenance of the appliance.**
- **Only competent persons are allowed to service or convert the appliance to another gas type.**
- **Gas appliances must have a stop cock fitted in the supply pipe work. The user must be familiar with the location and operation of this device in order to turn off the supply of gas in the event of an emergency.**
- **Unless otherwise stated, parts which have been protected by the manufacturer must not be adjusted by the installer.**
- **Take care when moving an appliance fitted with castors.**
- **The appliance must be serviced regularly by a qualified person. Service intervals should be agreed with the service provider.**
- **Check that no damage has occurred to the appliance, power cable, or plug during transit. If damage has occurred, do not use this appliance.**



- **Installation, periodic testing, repair and fixed wiring connections should only be undertaken by a competent electrician.**
- **Ensure power cable is routed free from the appliance to avoid damage.**
- **We recommend supplementary electrical protection with the use of a residual current device (RCD)**
- **The appliance has been designed and approved to use Falcon kick plates, non Falcon kick plates could potentially adversely affect the performance of the appliance by restricting the air to the appliance.**

THE MANUFACTURER DECLINES ALL RESPONSIBILITY FOR DAMAGE DUE TO INCORRECT INSTALLATION, TAMPERING, IMPROPER USE, FAULTY MAINTENANCE, FAILURE TO OBSERVE THE CURRENT REGULATIONS AND INCOMPETENCE.

THE MANUFACTURER RESERVES THE RIGHT TO MODIFY WITHOUT NOTICE THE APPLIANCE CHARACTERISTICS DESCRIBED IN THIS HANDBOOK.

CONTENTS

1. INSTALLATION

- 1.1 IMPORTANT INFORMATION**
- 1.2 POSITIONING**
- 1.3 CONNECTING TO THE MAINS**

2. INSTRUCTIONS FOR E600

- 4.1 FUNCTIONING**
- 4.2 SETTING**
- 4.3 USER INTERFACE**
- 4.4 MANUAL MODE**

3. CLEANING AND MAINTENANCE

- 5.1 ROUTINE MAINTENANCE**

SECTION 1 INSTALLATION

1.1 IMPORTANT INFORMATION

Read this handbook through carefully as it provides important information about safely installing, using and servicing the unit. Keep the handbook in a safe place for future reference by the various operators.

- The unit must be installed by professionally qualified personnel in accordance with the manufacturer's instructions.
- The unit must be used only by people who have been trained to use it.
- Do not leave the unit unattended during use.
- Turn the unit off in the event of a failure or malfunction. Repairs should only be carried out by an authorised repair centre using original parts.
- Failure to do so could compromise unit safety.

The unit conforms to the following standards:

- Low voltage directive 2006/95/EC;
- E.M.C. directive 2004/108/EC concerning electromagnetic compatibility;

1.2 POSITIONING

Remove the unit from the packaging and make sure it is in perfect condition.

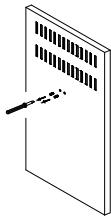
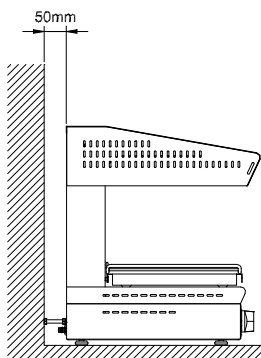

Figure 1

Before installing the appliance, remove the two screws blocking the heating element from the back (Refer to Figure 1)

Place the unit where it is going to be used, keeping it away from walls, flammable cladding materials or other flammable parts.

Level and adjust the height of the unit by means of the levelling feet.



Remove the protective film from the outer panels, pulling it away slowly so no traces of glue are left.

Do not obstruct the air flow or heat vents.

If you put the unit on a table, leave at least 50mm between the back of the unit and rear wall (Refer to Figure 2).

Figure 2

To wall mount the salamander use the wall-mounting brackets and screws and inserts suitable for the type of wall and unit weight.

1.3 CONNECTING TO THE MAINS

Electrical rating: 4.5kW

Electrical supply voltage: 400V 3N~ 50/60hz

Required electrical supply: 32A

Phase split: L1 6.52A, L2: 6.52A. L3: 6.52A

Single phase: 19.56A

- Before connecting unit to the mains, check that both voltage and frequency on rating plate are the same as those of the electrical supply system.
- The unit is delivered ready for use as indicated on rating plate located on the back.
- To connect unit to the mains, thread cable (cut down to the right length) through hole on the back of the appliance and connect to junction box on the right side. Fit the require plug to the unit for the electrical supply and connect it to a suitable that is properly earthed in accordance with current standards.
- For a direct connection to the mains, it is necessary to install a 4-pole switch between the unit and the mains, rated for the load and with contacts that have a minimum opening distance of 3mm.
When unit is running, check supply voltage is $\pm 10\%$ of rated voltage value.
- In addition, the unit must be connected to an equipotential system which must be checked following the guidelines of current regulations.

SECTION 2 INSTRUCTIONS FOR E600 (fitted with plate)

The unit should only be used for the designated purpose. Any other use is improper.

Do not leave appliance unattended when in use.



Figure 3

4.1 GRILL FUNCTION

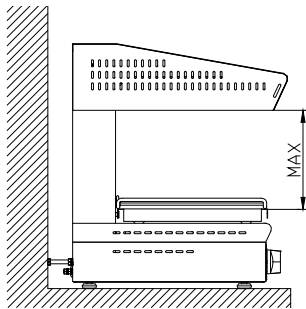

COOKING mode:

By adjusting the hood height, it is possible to regulate heat upon food to be cooked. The greater distance between the food and the heating element - the lower the heat intensity.

Figure 4

HOLD mode:

The grill hood must be at the maximum height above hob level (Refer to Figure 4). The alternating side heating elements keep food on the tray at the cooking temperature reached during the cooking cycle.

The central section will pulse off and on during operation. This provides evenness of grilling across the entire cooking surface.

4.2 SETTING

Before turning on the grill for the first time, remove all packaging material and clean unit thoroughly, removing any protective industrial grease as follows:

- Clean unit with a damp sponge and a mild detergent.
- Rinse grill with clean water.

4.3 USER INTERFACE



Figure 5



On/off button. When appliance is switched off - all functions are switched off as well.



Start/stop button allows you to start or stop cooking and hold modes.



Mode select button allows you to select either cooking or hold modes in case of manual cooking; in case of program selection you can pass from cooking mode to hold mode and vice versa.



- and + buttons increase or decrease cooking time and/or heat intensity of the hold mode



Central heating button allows you to set the cooking session with all resistances or just the central resistances.



Preset buttons cannot be used when the appliance is in START mode; thus the following instructions only refer to ON or STOP mode; you can select a program by briefly pressing the corresponding button. You can enter the program selection mode by holding the button down; you can then save current settings and go back to normal functioning by briefly pressing the same button again.

4.4 MANUAL MODE

Switch the grill on by pressing the ON/OFF button

Press MODE SELECT button to select the type of mode (cooking or hold – the corresponding LED above the display will come on)

Set time and intensity and press START or place the plate upon the plate detection device to start the session (cooking mode will terminate once the set time ends and a buzzer will sound); pressing the START/STOP button or removing the plate (the plate detection device switches appliance off) will cause the HOLD mode to switch off.

AUTOMATIC MODE

Switch the grill on by pressing the ON/OFF button

Select desired program by pressing P1, P2 or P3 button

Press **START** or place the plate upon the plate detection device as in the manual mode.

SETTING A PROGRAM

Switch the grill on by pressing the ON/OFF button

Hold down desired program button (P1, P2 or P3) until display starts flashing

Set cooking or hold mode by pressing SELECT/MODE button, then set time using the + and - buttons

If the cooking mode has been selected, it is possible to set a hold mode session at the end of the cooking session by pressing SELECT/MODE button immediately after setting the time and then setting heat intensity from 1 to 8. Save the program by pressing the button again. If you press the program button again without setting a hold mode session first, the cooking session only will be saved.

SWITCHING OFF

After use, switch off appliance using ON/OFF switch and omni-polar switch upstream of appliance.

SECTION 3 CLEANING AND MAINTENANCE

3.1 ROUTINE MAINTENANCE

At the end of each working day, the unit must be cleaned both for reasons of hygiene and also to prevent malfunctions.

Disconnect unit from electricity supply before starting.

Clean all stainless steel parts with warm, soapy water, rinse thoroughly and dry with care. Do not use products that contain chlorine (e.g. bleach).

Do not clean unit with jets of water or high pressure water. Do not use metal cleaning pads, brushes or scrapers made of ordinary steel. If necessary, use stainless steel wool, rubbing in the direction of satin finish.

If unit is left unused for any length of time, apply a thin protective layer of Vaseline oil over all stainless steel parts with a cloth and ensure that the room is regularly aired.

WIRING DIAGRAM

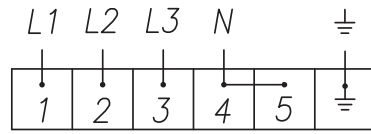

400V 3N~ 50/60hz

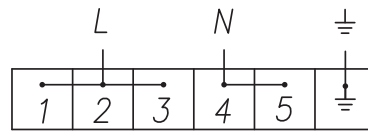

230V~ 50/60hz

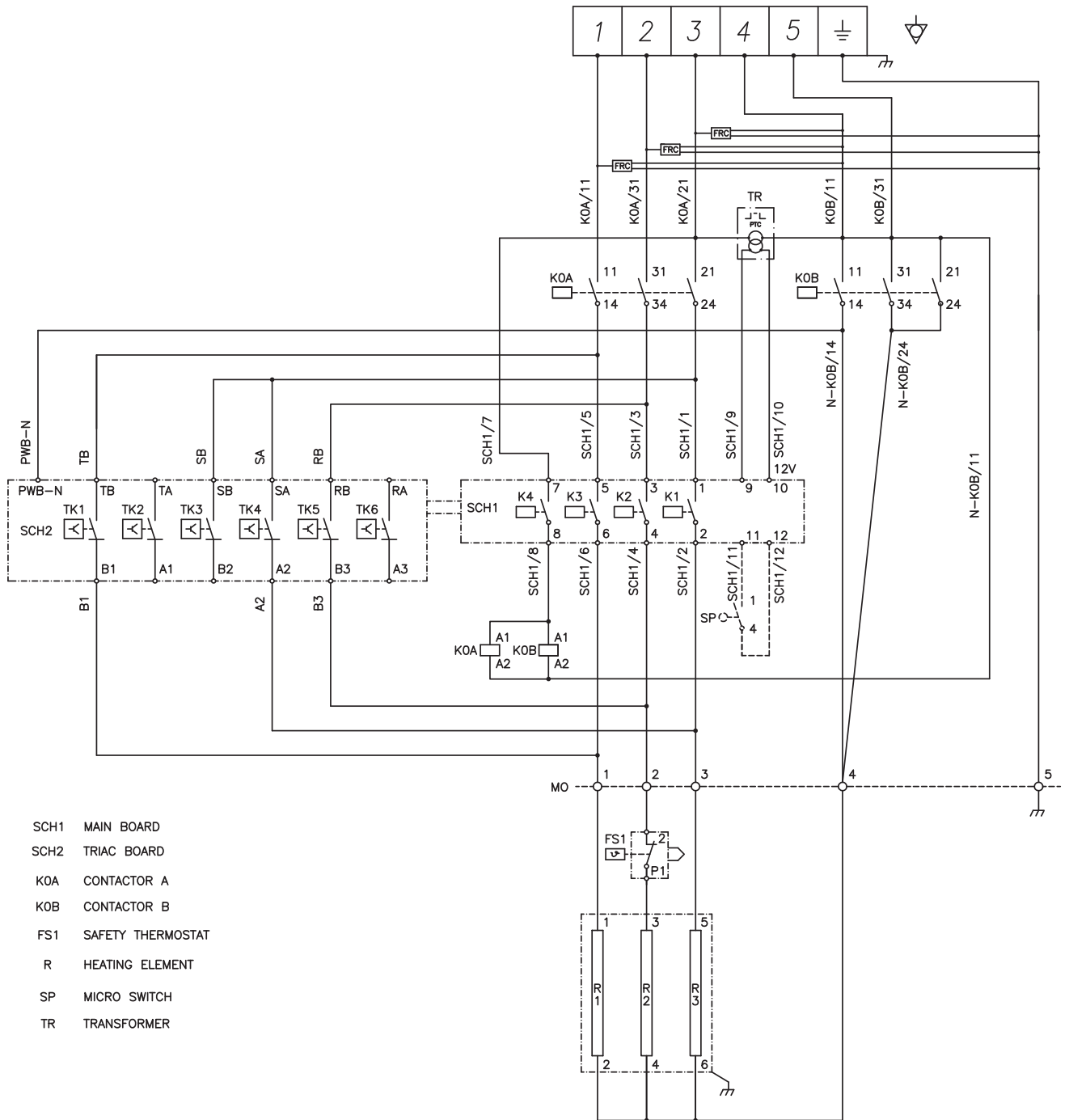

- SCH1 MAIN BOARD
- SCH2 TRIAC BOARD
- K0A CONTACTOR A
- K0B CONTACTOR B
- FS1 SAFETY THERMOSTAT
- R HEATING ELEMENT
- SP MICRO SWITCH
- TR TRANSFORMER